

TPE Weather Stripping - RP600 Series

Joinery Seals for Doors and Windows



Approvals

Fire Flammability index ≤ 5 when tested to AS1530.2.

Weather AUS/NZ: NCC various sections. AS2047, AS4055, AS/NZS 4420 Pt. 0 to 5 & AS/NZS 1170.

UK/EU: Approved Document L1 & L2. Tests above are similar to BS 5368 & BS 7386.

Energy NCC Pt. 3.12.3.3 & J3.4.

RP680

Location: Proprietary aluminium or PVC door and window frame groove where dimensions suit.

Compression: 1mm to 3mm.

Finish: Black.

Fixing: Slide fit into aluminium or rigid PVC groove where dimensions suit. (Channel not supplied).

Sizes: 100m, 24m.

Approvals: Fire & Energy.

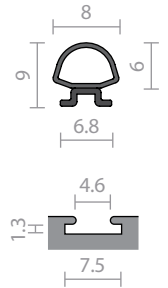

Recommended groove dimensions. Channel not supplied.

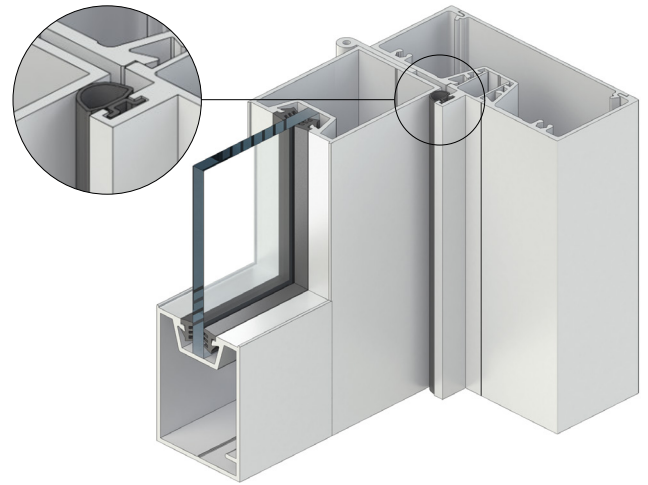

Raven Seals Cut Energy Use by 50% !

David Saunders, architect of S2 Design designed and built his private home in metropolitan Melbourne, providing a best-practice example of environmentally aware and sustainable living.

With a focus on reducing energy consumption, Raven door and window seals were installed throughout the home to eliminate the loss of energy through gaps in doors and windows and to provide acoustic, weather and vermin protection.

David's home energy consumption is automatically monitored allowing David to see exactly how much energy the home is using at any time or over any period.

The energy consumption used to heat and cool the home was immediately reduced by 50% with the installation of Raven Door & Window seals that equated to a cost saving of over \$1,200 per year!

Raven Door & Window seals are a low cost and effective solution to an expensive problem; David found, the fitting of Raven seals to his home will pay for themselves in less than 2 years.